

**CEBB
HYDRONIC
HEATING UNIT
INSTALLATION
MANUAL**

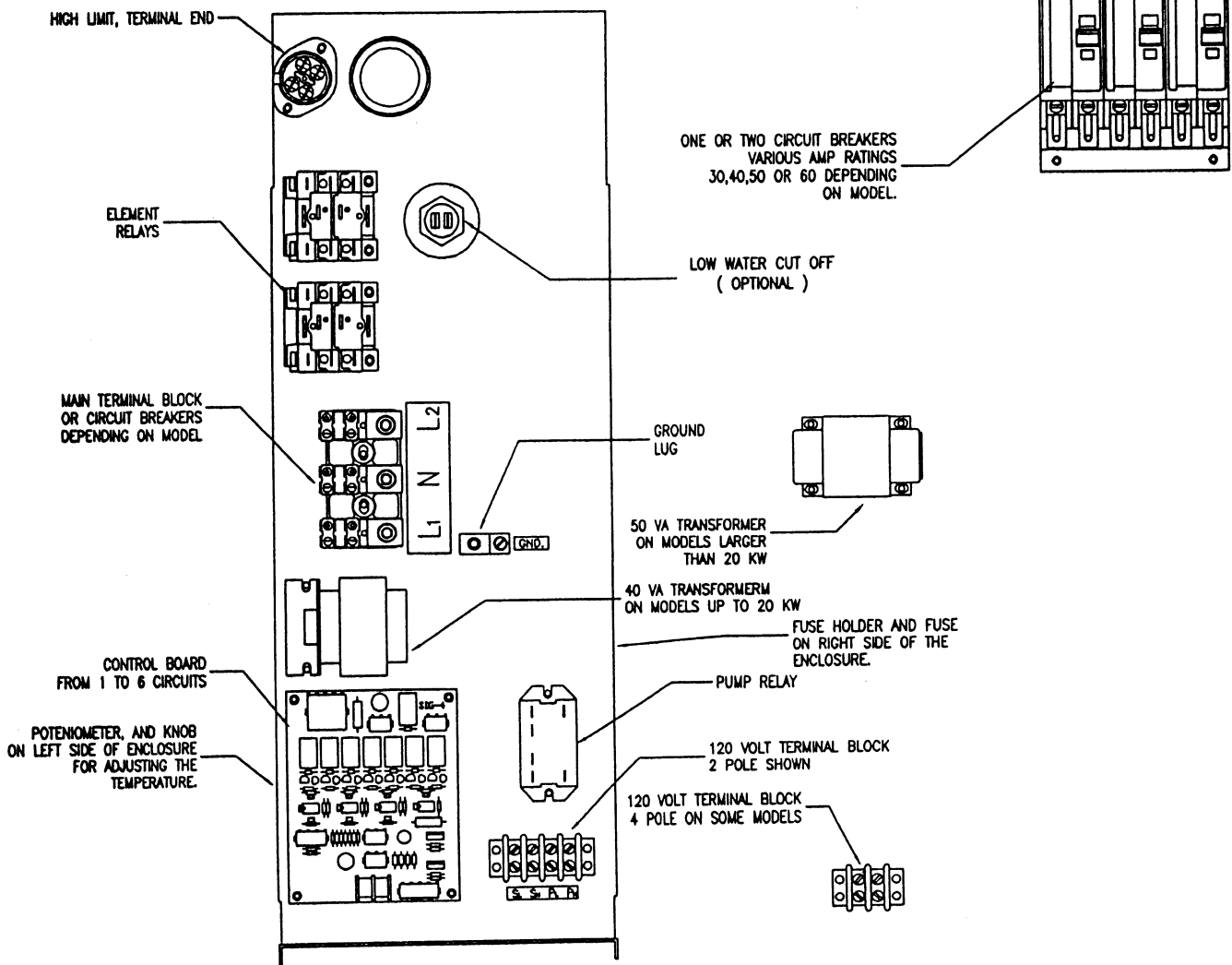
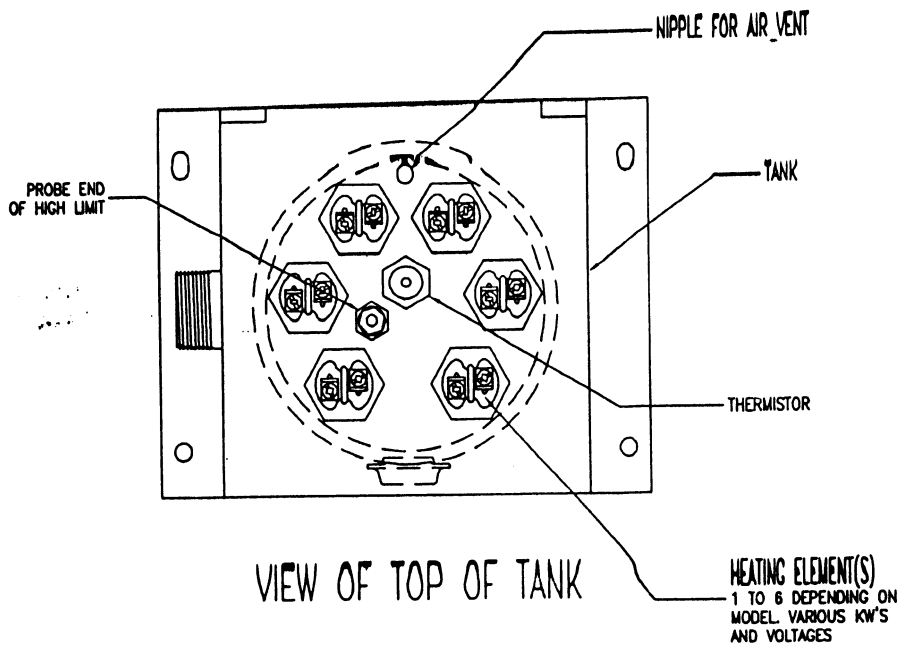

VIEW FROM FRONT IN TO CONTROL PANEL

CEBB MODEL HYDRONIC HEATING UNIT

Introduction

Your Electric Boiler has been designed to exacting specifications to provide controlled and efficient heating and maximum service life. It's operation differs from most fuel fired boilers in that almost 100% of the heat generated by the immersed elements is transferred to the water.

The electric boiler is controlled differently than fossil fuel fired boilers where the burners function independently of the circulating system and thermostat. With an electric boiler the thermostat controls both the circulating pump and the heating elements energizing both at the same time. This is necessary because the compact tank permits rapid heating of the water. The Solid State Control System stages the power to the elements thus reducing sudden loading of the electrical service.

Specifications

| Model | kW | Volts | Phase | Amps | Maximum Breaker Size |
|---------------|------|-------|-------|-------|----------------------|
| CEBB-3 | 3 | 240 | 1 | 12.5 | 20 |
| CEBB-5 | 5 | 240 | 1 | 20.8 | 30 |
| CEBB-6 | 6 | 240 | 1 | 25.0 | 40 |
| CEBB-8 | 8 | 240 | 1 | 33.3 | 50 |
| CEBB-9 | 9 | 240 | 1 | 37.5 | 50 |
| CEBB-10 | 10 | 240 | 1 | 41.7 | 60 |
| CEBB-15 | 15 | 240 | 1 | 62.5 | 60/30 |
| CEBB-18 | 18 | 240 | 1 | 75.0 | 60/50 |
| CEBB-20 | 20 | 240 | 1 | 83.3 | 60/60 |
| CEBB-23 | 23 | 240 | 1 | 95.8 | 60/50/30 |
| CEBB-25 | 25 | 240 | 1 | 104.2 | 60/60/30 |
| CEBB-28 | 28 | 240 | 1 | 116.7 | 60/60/50 |
| CEBB-30 | 30 | 240 | 1 | 125.0 | 60/60/60 |
| CEBB-208-15 | 15 | 208 | 3 | 41.7 | |
| CEBB-208-22.5 | 22.5 | 208 | 3 | 62.5 | 40/40 |
| CEBB-208-30 | 30 | 208 | 3 | 83.3 | 50/50 |
| CEBB-480-15 | 15 | 480 | 3 | 18.0 | |
| CEBB-480-30 | 30 | 480 | 3 | 36.1 | |

Control Voltage 24 Vac
Boiler Capacity - approx. 2 gallon steel tank
Shipping Weight about 85 lbs.
Inlet and Outlet Pipe Size 1 1/4" NPT
Pump Switch Capacity 1 HP / 120 V
Recommended Maximum Operating Temperature 180° F
Recommended Operating Pressure 15 psi
Maximum Operating Pressure 28 psi

Note: The control transformer is sized to power only the internal controls. External devices must be powered from a separate power source.

New Unit Inspection

All units are inspected and tested at the factory prior to shipment. On receipt of your new unit be sure to check for damage which may have occurred in shipping. Any such damage should be reported immediately to the carrier.

Unpacking

The "Hydronic Boiler" is shipped to you in one carton which contains the basic unit, plus a quantity of smaller packages packed around it which contain fittings and accessories required to complete the assembly of the unit.

***NEVER INSTALL A DAMAGED UNIT**

System Design

For proper operation of the heating system, the hydronic boiler, the radiation/in-floor system, the maximum heat loss of the building must be considered. The boiler selected should provide between 110% and 130% of the maximum design heat loss of the building.

The radiation system should be designed to dissipate 110% of the boiler's capacity at the desired operating temperature of the system. Hot water radiators are usually rated as being able to dissipate varying amounts of heat at varying operating temperatures.

The recommended cold fill pressure of the system is 12 psi, this pressure should leave at least 4 psi at the highest point in the heating system. Pressure will decrease at a rate of 0.433 psi per foot above

the fill point. An expansion tank must be included to allow for approximately 4% expansion of the water in the entire system (that is the boiler all radiators and pipes). As water in the system is heated the pressure will increase, but a properly sized expansion tank will prevent the pressure from exceeding the maximum recommended operating pressure (28 psi).

The radiators/in-floor should be arranged in loops so that as many radiators/in-floor are in parallel as possible since if too many radiators/loops are connected in series, the accumulated heat loss in each radiator/loop may cause uneven heating. The minimum recommended G.P.M. must be used, but higher G.P.M.'s will give more even heating. If a number of parallel loops are used, valves/pumps are usually required to balance the flow in each radiator/loop to provide uniform heating.

A zoned heating system is also possible with separate heating zones and individual thermostats in each zone. See Fig. 3 for sample electrical connections and plumbing of zoned systems.

INSTALLATION

Location

- I) The site selected for installation of your boiler should leave at least 24" of clear space in front and above the unit. The sides require only enough room for plumbing and electrical connections (see Fig. 1). The rear and base of the unit are considered as "Zero Clearance" faces (see item III and Fig. 1). If wall mounting is chosen, ensure that the wall can withstand the weight of the unit including water (approximately 115 lbs.). Two brackets are provided on top and are drilled for 3/8" bolts or screws, these are for wall mounting. Holes are also provided in the base for floor mounting.
- II) The space selected should be well ventilated and kept normally below 77° F.
- III) Though the unit is suitable for floor or wall mount, only faces indicated as "Zero Clearances" may be mounted against combustibile surfaces.
- IV) Units must be square and vertical with the outlet at the top.
- 22) The circulation pump should be connected to the unit bottom inlet fitting (see Fig. 2) 1 1/4" NPT.

Mechanical Installation

- I) Refer to Fig. 2 and 2a and study thoroughly before installation.
- II) Packed with your boiler is the following.

- 1 - Temperature/Pressure Gauge.
- 1 - 30 lb. Relief Valve.
- 2 - 1 1/4" x 1 1/4" x 3/4" NPT "Tee" Unit
- 1 - Adaptor 3/4" x NPT to 1/4" NPT Bushing.

These are sub-assembly components to boiler as indicated in Fig. 2 and 2a.

- III) Mount unit as per instructions under "location".
- IV) Install inlet and outlet piping.
- V) An expansion tank must be installed upstream of the boiler (see attached diagram). It must be selected and sized by calculating the total water volume in the system and ensuring that the vessel is sized to allow for 4% expansion of water (see system design and refer to installation instructions provided with expansion tank).

Pump Installation

The circulating pump should be positioned as close to the unit as possible, with the delivery arranged to pump into the tank inlet on the bottom of the unit (see Fig. 2).

The pump is powered by the "Hydronic Heater" through terminals PL and PN located on the 120 volt terminal block (lower terminal in unit see Fig. 4a or 4b). The pump starts on heating demand signal, and stops after the thermostat is satisfied.

If desired, the pump may be operated continuously during the heating season, this offers certain advantages as follows:

- Improved comfort in some radiation systems by distributing heat energy more evenly, with smaller changes in radiator average temperatures.
- Minimize the noise distraction associated with the starting and stopping of the pump.
- Maximize the life of the pump motor by minimizing the wear associated with frequent starts and stops.

Should you decide to wire the pump in this manner, it must be wired through the same supply as the boiler to prevent the pump from being turned off while the boiler is still powered.

Supply connections to the motor must be completed at the motor in an internal or attached approved junction box.

Electrical Installation

All wiring must comply with local regulations and codes. Verify the "Name Plate Rating" to properly size conductors, switch and over current protection.

Cautions

- 1) **"Caution Before installation, ensure that the local electrical inspection authority will accept connection of this equipment to the existing panel."**
- 2) **"Caution: This equipment may only be installed and tested by qualified personnel."**
- 3) The electrical power supply should be checked for adequacy for the proposed additional load. The boiler requires connection of power to the terminals of the circuit breakers, see Fig. 4a and 4b. See the name plate for the ratings of each individual circuit.

Low Voltage Terminal Block Connection

- Connect Thermostat to T1 T2 (if the system is zoned, the end switches of all the zone valves should be connected in parallel across T1 T2).

Thermostat Anticipator

- 1) The thermostat anticipator settings recommended are 0.2 Amps. Failure to correctly adjust this setting will result in unsatisfactory comfort conditions and could result in permanent damage to the thermostat.
- 2.) This setting may have to be adjusted slightly to ideally match the boiler control system to the thermostat, as well as to overcome the normal inertia of the radiation system. A setting too low will be characterized by a short cycle which does not allow the space temperature to be satisfied before shutting down the boiler. A setting too high will be characterized by a long cycle which allows large swings and overshoot in the space temperature. Compensating adjustments should be made as required but should not exceed 0.1 amps per adjustment.
- 3.) In zoned systems where room thermostats control zone valves or external relays, the thermostat anticipator should be set to match the current draw of the zone valve being used.

Thermostat Connection

All external control wiring is 24 Vac. After ensuring the boiler and the entire radiation system is full of water, connect the low voltage thermostat wires to T1 and T2 on the low voltage terminal strip. Pass all thermostat wires through the K.O.'s provided on the enclosure.

Aquastat

All boilers have an internal aquastat with an external temperature control. Care should be exercised in setting the water temperature. If the aquastat setting is too low, some heating capacity may be lost.

Start Up

A new system must be thoroughly cleaned, flushed and drained, then refilled with clean water. Foreign material circulating through the system could be detrimental to the pump and to the heat transfer efficiency of the system and may lead to future problems.

Close maintenance valve and open purge valve. Run water through the system and out the purge valve for at least five minutes to ensure that there is no air in the system.

The automatic air vent is for the purpose of removing air from the vessel to prevent the elements from burning out. Additional air vents installed at high points of the system would be useful in removing air that accumulates from the water supply line. **Ensure that ALL EXCESS AIR IS REMOVED FROM VESSEL JUST BEFORE ELECTRICAL POWER IS TURNED ON.**

Oil the pump (if applicable) and otherwise prepare it for operation according to the manufacturer's instructions.

CAUTION ELEMENTS WILL BURN OUT IF THE BOILER IS NOT FULL OF WATER WHEN ELECTRICAL POWER IS TURNED ON. DO NOT CONNECT THERMOSTAT WIRES UNTIL SYSTEM IS FULL OF WATER.

Check List

- 1.) Plumbing complete
- 2.) System flushed
- 3.) System free of air
- 4.) Pump rotates freely
- 5.) Thermostat connected
- 6.) Thermostat anticipator set
- 7.) Electrical supply connections complete

Maintenance

At the start of each heating season, lubricate the circulation pump and motor (if applicable) with 6 to 10 drops of SAE 20 non detergent oil. Review and follow start up procedure.

Troubleshooting Guide

| Problem | Correction |
|--|---|
| a) Boiler not heating, water cool | -check power supply, fuses breakers etc. -check thermostat setting -check aquastat setting |
| b) Boiler heating pipes cool | -check for air in system -check pump circulation -check all valves |
| c) Boiler rapid cycles | -check anticipator setting -check pump circulation -check for flow stoppage (air lock etc.) |
| d) Boiler operates continuously space overheats | -check anticipator setting |
| e) Boiler noisy | -oversized pump -too high flow rate -too low flow rate -pump location incorrect |
| f) Boiler not heating enough | -insufficient capacity -burnt elements -flow rate too low |
| g) Pressure too high (above 28 psi) | -defective expansion tank -defective automatic fill valve -expansion tank too small |
| h) Safety relief valve dripping | -check expansion tank -flush relief valve |

See additional trouble shooting at back of manual.

If you encounter problems with this boiler, please call: 1-800-465-4114

CONCEPT MANUFACTURING INC. LIMITED WARRANTY

Two Year Warranty Concept Manufacturing Inc. (the "Manufacturer") warrants its Hydronic Boiler (the "Boiler") to be free from defects in material and workmanship under normal use and maintenance for a period of two (2) years from the date of original installation.

If any part of the Boiler is found by the Manufacturer, as sole judge, to be defective in material or workmanship, the Manufacturer, at its sole discretion, agrees to:

- (i) Repair any defect;
- (ii) replace any defective Boiler; or
- (iii) refund the original purchase price of the Boiler.

The Manufacturer, at its sole discretion, reserves the right, at any time during the warranty period, to refund the original purchase price to the current owner of the Boiler regardless of any prior attempt by the Manufacturer to repair or replace that Boiler.

The obligation of the Manufacturer to repair, replace or refund the purchase price exists provided the defective part or complete unit is returned to the Manufacturer. **ANY AND ALL TRANSPORTATION COSTS WILL BE BORNE BY THE PURCHASER.**

Repair, replacement or refund of any defective part or unit shall be considered as complete fulfillment of this warranty.

THIS WARRANTY DOES NOT APPLY TO:

1. Labor or other costs incurred for diagnosing, repairing, removing, installing, reinstalling, shipping, servicing or handling of any defective part or complete unit;
2. Costs incurred for normal maintenance;
3. The workmanship of any installer of the Boiler. In addition, this warranty does not assume any liability of any nature for unsatisfactory performance caused by improper installation;
4. Damage or repair as a consequence of storage and handling, improper or careless installation, improper maintenance, or misuse or neglect as determined by the Manufacturer as sole judge;
5. Damage as a consequence of misapplication, abuse, improper servicing, unauthorized alteration, improper operation or usage contrary to the Manufacturer's direction, design or specifications, as to any and all of which the Manufacturer shall be the sole judge;
6. Damage as a consequence of electrical surges, inadequacy or interruption of electrical services or corrosion, whether caused by chemicals or the environment;
7. Damages as a consequence of floods, winds, fires, lightning, freezing conditions or other conditions beyond the control of the Manufacturer.

LIMITATION OF WARRANTY THIS LIMITED WARRANTY IS IN LIEU OF ALL OTHER WARRANTIES WHETHER EXPRESS OR IMPLIED, AND ALL SUCH OTHER WARRANTIES, INCLUDING WITHOUT LIMITATION IMPLIED WARRANTIES OF MERCHANTABILITY OR FITNESS FOR A PARTICULAR PURPOSE, ARE HEREBY DISCLAIMED AND EXCLUDED FROM THIS LIMITED WARRANTY.

THE MANUFACTURER'S LIABILITY ON ANY CLAIM OF ANY KIND, INCLUDING NEGLIGENCE, WITH RESPECT TO THE GOODS OR SERVICES COVERED HEREUNDER, SHALL IN NO WAY EXCEED THE PURCHASE PRICE OF THE BOILER, OR PART THEREOF, WHICH GIVES RISE TO THE CLAIM. IN NO EVENT SHALL THE MANUFACTURER BE LIABLE FOR SPECIAL, INCIDENTAL, INDIRECT, OR CONSEQUENTIAL DAMAGES, OR ANY DAMAGES IN THE NATURE OF PENALTIES. ALL WORK UNDER THE TERMS OF THIS WARRANTY SHALL BE PERFORMED DURING NORMAL WORKING HOURS.

ALL REPLACEMENT PARTS OR UNITS, WHETHER NEW OR REMANUFACTURED, ASSUME AS THEIR WARRANTY PERIOD ONLY THE REMAINING TIME PERIOD OF THIS WARRANTY.

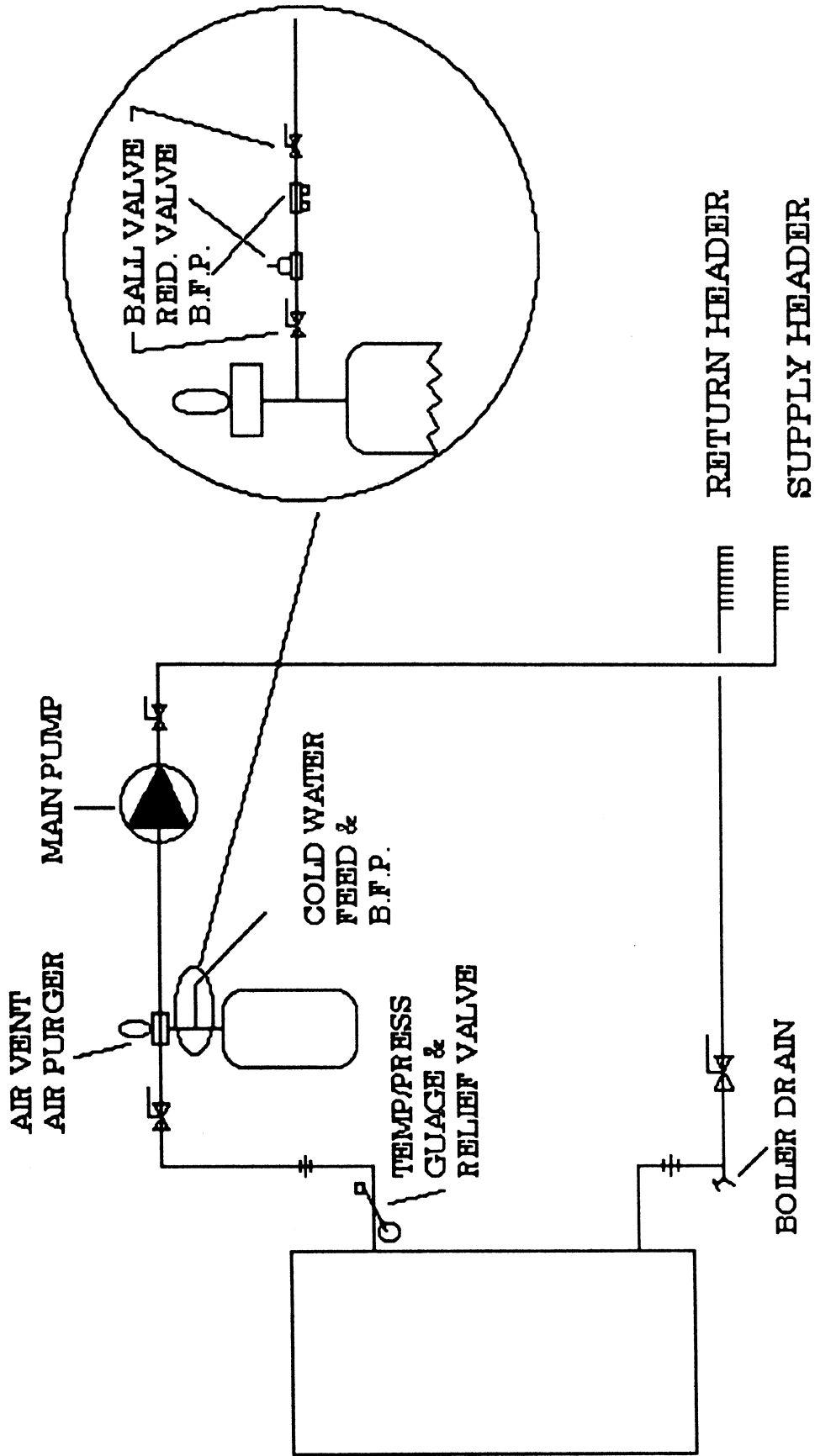

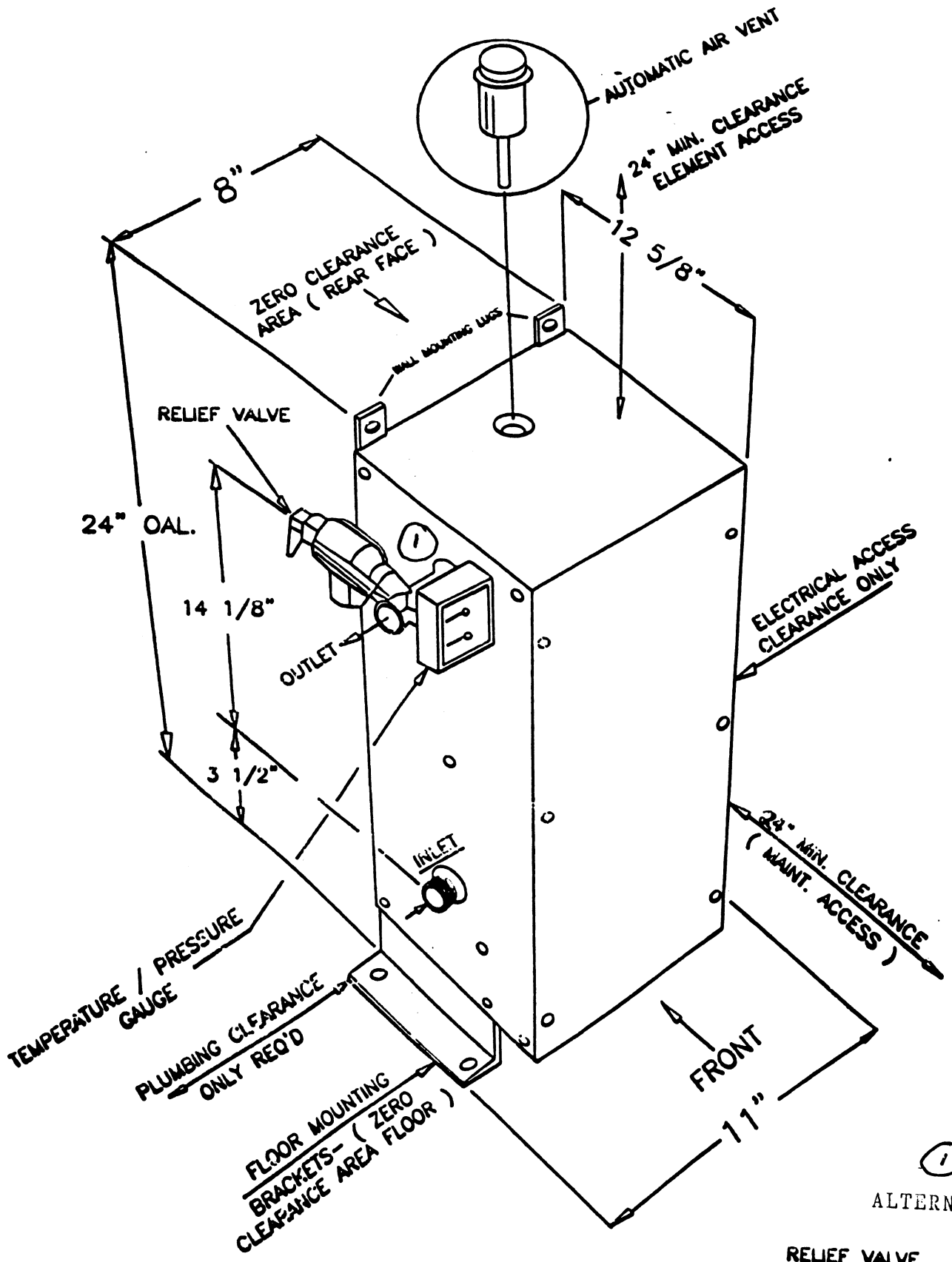

(1)

ALTERNATE

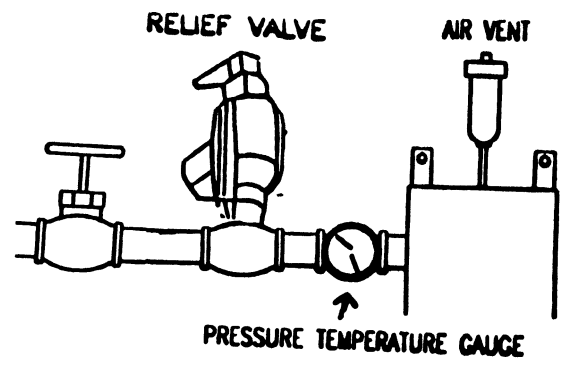
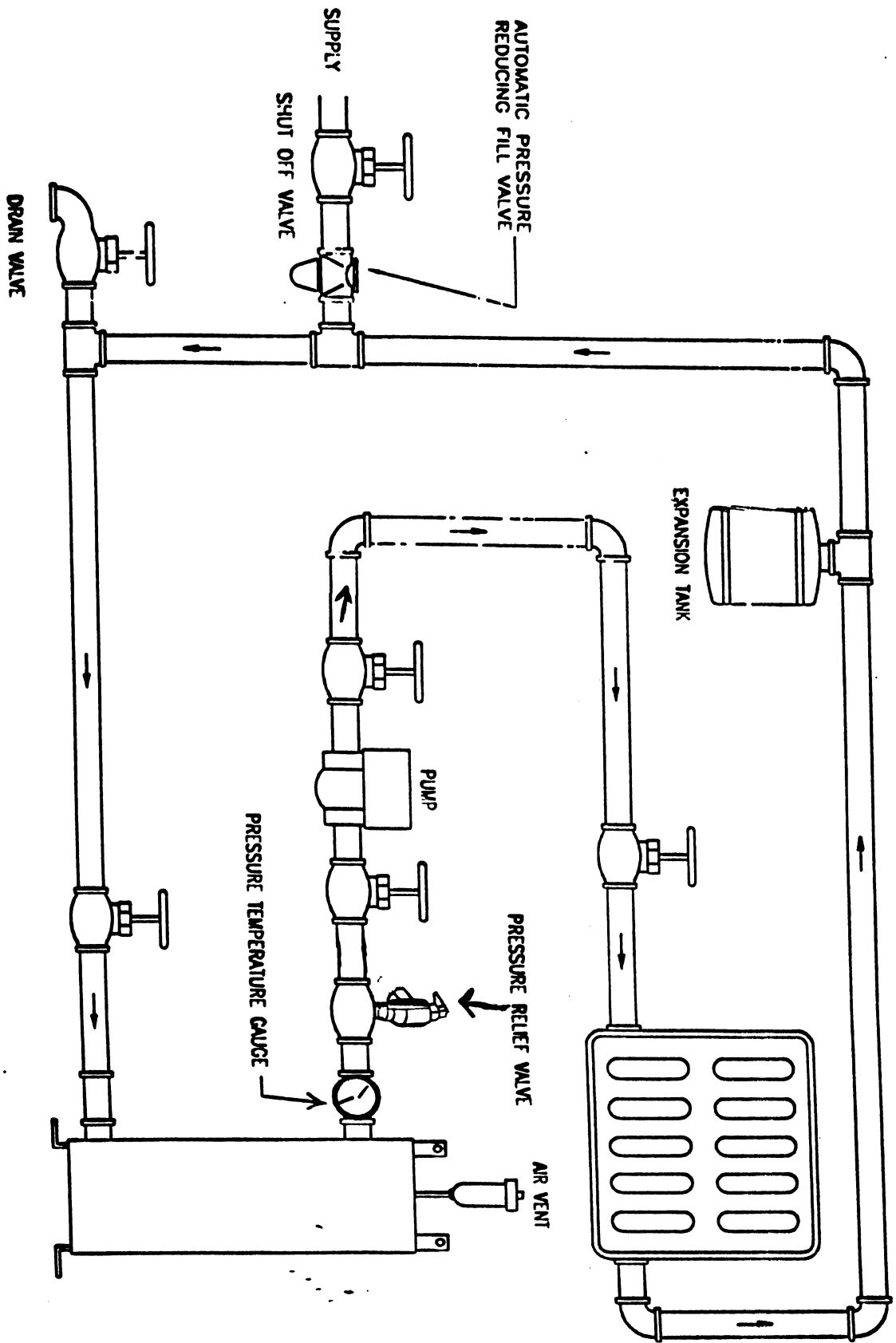
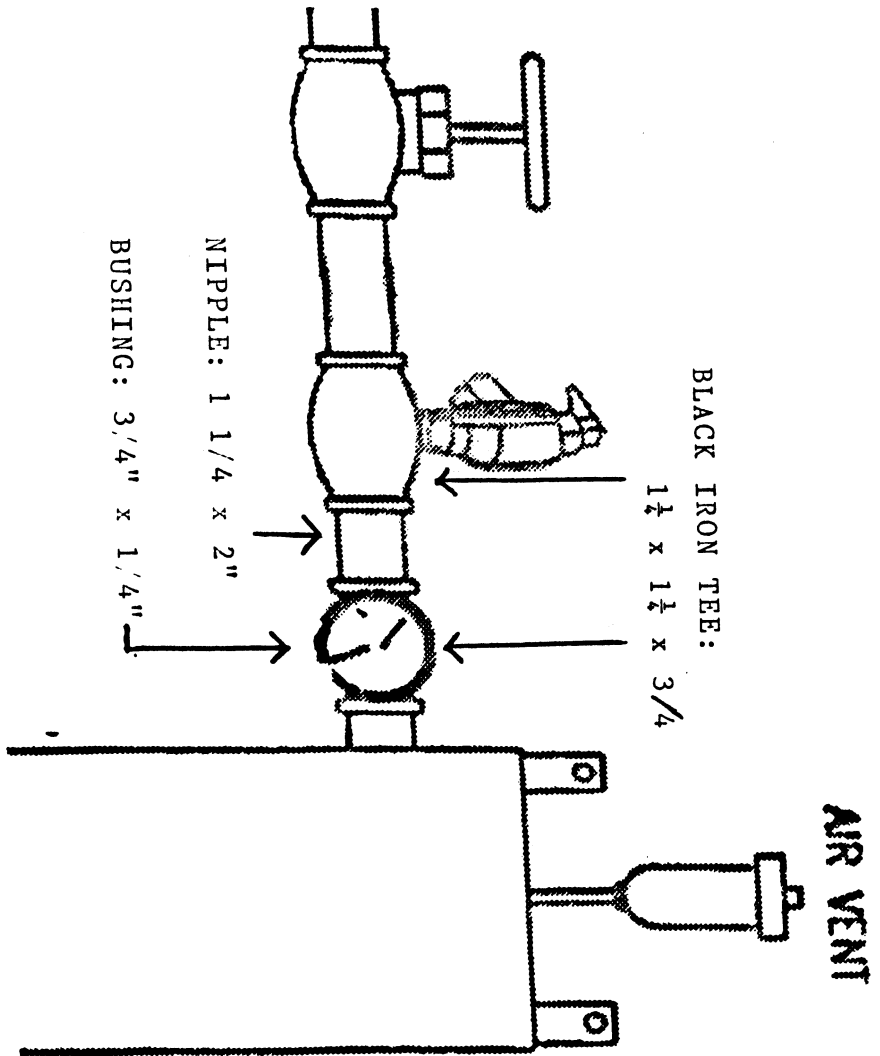

Fig. 1



MECHANICAL INSTALLATION

FIG. 2



MECHANICAL INSTALLATION
 FIG. 2 a

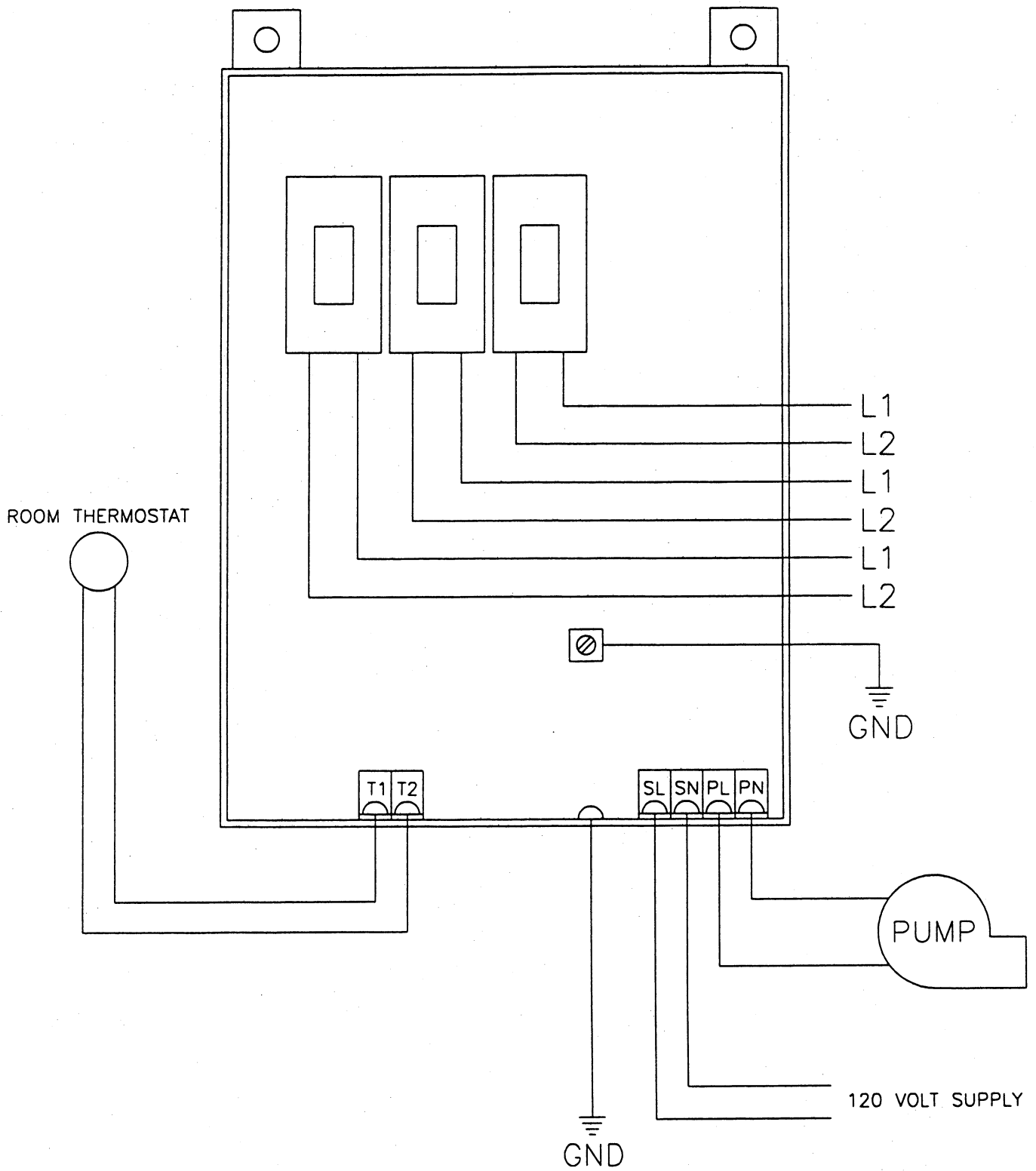

ELECTRICAL WIRING

Fig. 4a

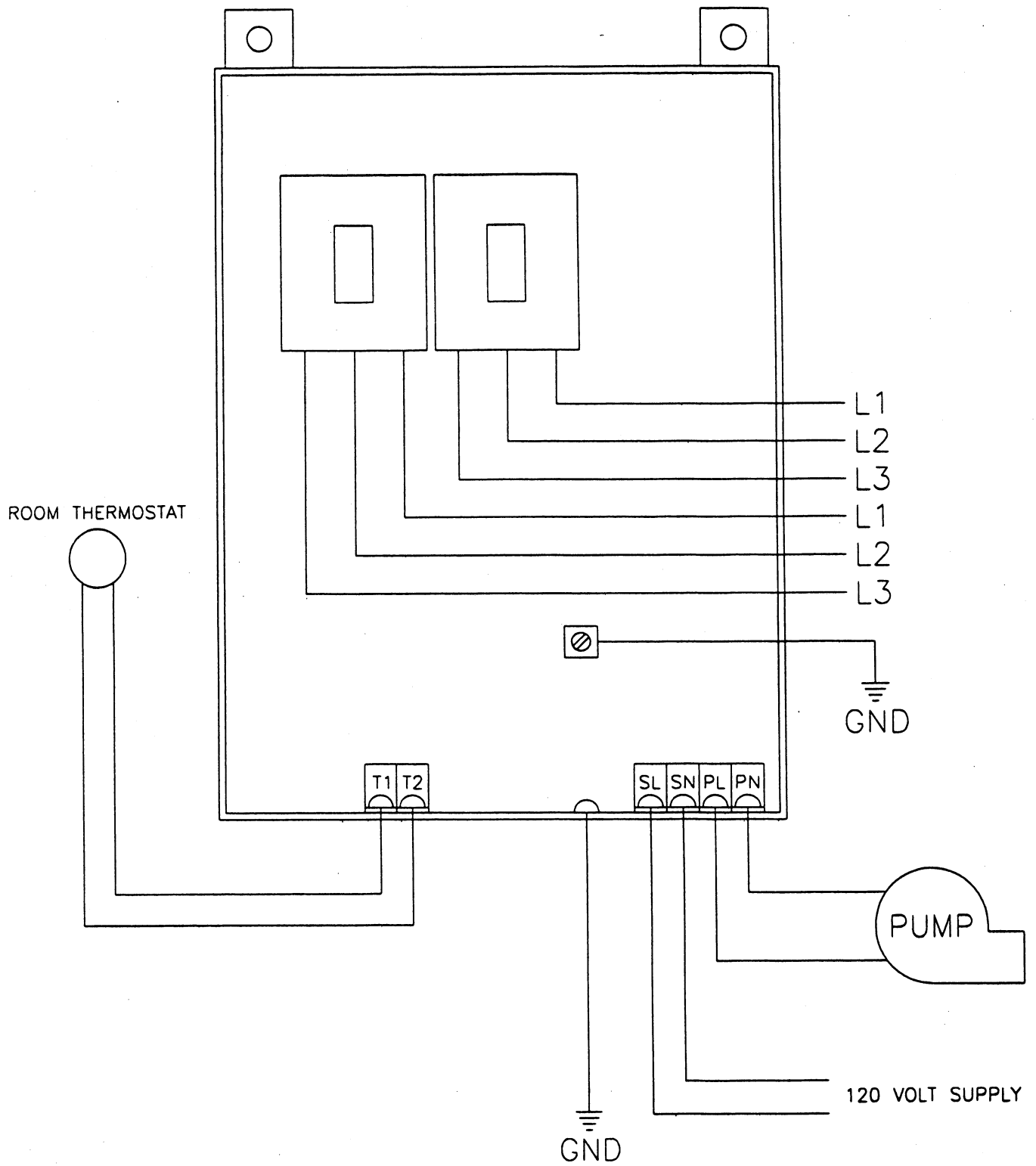

ELECTRICAL WIRING

Fig. 4b



CEB / CEBB BOILER: TROUBLE - SHOOTING INFORMATION

- 1) Ensure that there is 120 volt power to terminals S1 and Sn on the terminal block at the lower right hand side.
- 2) Check that there is 24 volts AC power on the transformer where the two red wires are connected. If not, replace the transformer.
- 3) Short out terminals T1 and T2. These are the two terminals on the middle bottom of the circuit board.

This should energize the relay at the right of the circuit board. You should hear it click on. If not, check that there is 24 volts on the two terminals with the purple wires.

- If there is no power at the purple wires, replace the board.
- If there is power, but the relay is not turning on, replace the relay

- 3 (a) When the relay clicks on, it will energize the circuit board and supply 120 volt power to the pump - Terminals P1 and Pn.
- 4) Turn up the "Aquastat" (the potentiometer) on the left hand side of the boiler. The board should now start, energizing the power relays for each element at the top of the boiler. You should see the red lights on the circuit board start to come on. This may take a few moments. If the lights do not come on, replace the board (do numbers 1 to 4 firstly!).
- 5) If the red lights come on the circuit board, but the power relays are not coming on, then the low water cut-off (the part with 2 pink wires going into it), or the high limit control (the part with 2 tan color wire going into it) are preventing them from coming on.
 - Try shorting out the low water cut-off (its at the top middle of the boiler). If the power relays come on, then the water level is low or the switch is defective.
 - Try shorting out the high limit(s). It is in the top left and right corners (only in the left corner on the latest model).
- 6) If the temperature controller does not appear to be operating, or if the boiler is running on the high limit, or the temperature does not appear to be rising:
 - Try pulling the 2 grey wires from the circuit board. If the power relays come on instantly, the Thermister needs to be replaced (located at the top of the boiler - at the other end of the grey wires
 - If the power relays do not come on after removing the grey wires on the board, then the board needs replacing.

If the above steps do not cause the boiler to operate properly, please call as at 1 - 800 - 465 4114.